**Petroleum and natural gas
industries — Factory bends,
fittings and flanges for pipeline
transportation systems —**

**Part 3:
Flanges**

*Industries du pétrole et du gaz naturel — Coudes d'usine, raccords et
brides pour systèmes de transport par conduites —*

Partie 3: Brides





© ISO 2022

All rights reserved. Unless otherwise specified, or required in the context of its implementation, no part of this publication may be reproduced or utilized otherwise in any form or by any means, electronic or mechanical, including photocopying, or posting on the internet or an intranet, without prior written permission. Permission can be requested from either ISO at the address below or ISO's member body in the country of the requester.

ISO copyright office
CP 401 • Ch. de Blandonnet 8
CH-1214 Vernier, Geneva
Phone: +41 22 749 01 11
Email: copyright@iso.org
Website: www.iso.org

Published in Switzerland

Contents

Page

Foreword	iv
1 Scope	1
2 Normative references	1
3 Terms and definitions	2
4 Symbols and abbreviated terms	3
4.1 Symbols.....	3
4.2 Abbreviated terms.....	4
5 Designation of flanges	4
6 Pressure class and design	5
7 Information supplied by the purchaser	6
7.1 Principal information.....	6
7.2 Supplementary information.....	6
8 Manufacturing	6
8.1 Manufacturing procedure specification.....	6
8.2 Starting material.....	7
8.3 Hubs.....	7
8.4 Heat treatment.....	7
9 Testing and inspection	7
9.1 General requirements.....	7
9.2 Extent of testing and inspection.....	7
9.3 Chemical composition.....	8
9.4 Physical testing.....	9
9.4.1 Preparation of test pieces.....	9
9.4.2 Tensile testing.....	9
9.4.3 Charpy V-notch impact tests.....	11
9.4.4 Hardness requirements.....	12
9.4.5 Metallographic examination.....	13
9.4.6 HIC tests.....	13
9.4.7 SSC tests.....	13
9.5 Non-destructive testing.....	13
9.5.1 NDT procedures and personnel.....	13
9.5.2 Forging preparation.....	13
9.5.3 Visual inspection.....	13
9.5.4 MT/PT inspection.....	14
9.5.5 Ultrasonic inspection.....	14
9.6 Dimensions.....	14
9.6.1 Flange dimensions.....	14
9.6.2 Tolerances.....	15
9.6.3 Flange-face finish.....	15
9.7 Hydrostatic testing.....	15
9.8 Weldability.....	15
9.9 Repair welding.....	15
10 Documentation	16
10.1 Inspection document.....	16
10.2 Manufacturing record book.....	16
11 Marking	16
Bibliography	18

Foreword

ISO (the International Organization for Standardization) is a worldwide federation of national standards bodies (ISO member bodies). The work of preparing International Standards is normally carried out through ISO technical committees. Each member body interested in a subject for which a technical committee has been established has the right to be represented on that committee. International organizations, governmental and non-governmental, in liaison with ISO, also take part in the work. ISO collaborates closely with the International Electrotechnical Commission (IEC) on all matters of electrotechnical standardization.

The procedures used to develop this document and those intended for its further maintenance are described in the ISO/IEC Directives, Part 1. In particular, the different approval criteria needed for the different types of ISO documents should be noted. This document was drafted in accordance with the editorial rules of the ISO/IEC Directives, Part 2 (see www.iso.org/directives).

Attention is drawn to the possibility that some of the elements of this document may be the subject of patent rights. ISO shall not be held responsible for identifying any or all such patent rights. Details of any patent rights identified during the development of the document will be in the Introduction and/or on the ISO list of patent declarations received (see www.iso.org/patents).

Any trade name used in this document is information given for the convenience of users and does not constitute an endorsement.

For an explanation of the voluntary nature of standards, the meaning of ISO specific terms and expressions related to conformity assessment, as well as information about ISO's adherence to the World Trade Organization (WTO) principles in the Technical Barriers to Trade (TBT), see www.iso.org/iso/foreword.html.

This document was prepared by Technical Committee ISO/TC 67, *Materials, equipment and offshore structures for petroleum, petrochemical and natural gas industries*, Subcommittee SC 2 *Pipeline transportation systems*.

This second edition cancels and replaces the first edition (ISO 15590-3:2004), which has been technically revised. The main changes compared to the previous edition are as follows:

- a) changed title;
- b) added the possibility to execute NDE following the International Standards and EN and ASTM standards;
- c) updated pressure-containment calculations in line with ASME VIII Division 1 or Division 2;
- d) updated manufacturing of Hubs, now in line with ASME B16.5;
- e) updated heat treatment subclause;
- f) modified the chemical analysis in [Table 4](#);
- g) reviewed forging preparation requirements;
- h) modified dimension of flanges to be in accordance with ASME B16.5, ASME B16.36, ASME B16.47, ANSI/MSS SP-44;
- i) reviewed tolerances to be in accordance with manufacturing standard;
- j) reviewed flange-face finish to be in accordance with manufacturing standard;
- k) updated applicable standards relating to HIC and SSC;
- l) modified Marking to be in accordance with ASME B16.5 requirements.

A list of all parts in the ISO 15590 series can be found on the ISO website.

Any feedback or questions on this document should be directed to the user's national standards body. A complete listing of these bodies can be found at www.iso.org/members.html.

Petroleum and natural gas industries — Factory bends, fittings and flanges for pipeline transportation systems —

Part 3: Flanges

1 Scope

This document specifies the technical requirements for carbon steel and low-alloy steel forged flanges for use in pipeline transportation systems for the petroleum and natural gas industries as defined in ISO 13623.

This document applies to weldneck and blind flanges (full face, raised face, and RTJ groove) as well as anchor, swivel-ring flanges and orifice flanges.

This document designates those categories of flanges that meet the industry's need to match ISO 3183 pipe. These flanges are for normal and low-temperature service and include supplementary requirements where required for sour service.

Materials for, or the attachment of, factory-welded extensions, bolting materials, gaskets, slip-on flanges or flanged fittings are not covered by this document.

This document is not applicable to integrally cast or forged flanges for valves, pumps or other equipment.

This document does not cover the selection of the flange category or pressure class. Sizes and pressure classes listed in ISO 7005-1 and applicable to this document are as follows:

- DN 10 (NPS 1/2) to DN 1500 (NPS 60);
- PN 20 (class 150), PN 50 (class 300), PN 100 (class 600), PN 150 (class 900), PN 250 (class 1500), PN 420 (class 2500).

2 Normative references

The following documents are referred to in the text in such a way that some or all of their content constitutes requirements of this document. For dated references, only the edition cited applies. For undated references, the latest edition of the referenced document (including any amendments) applies.

ISO 148-1, *Metallic materials — Charpy pendulum impact test — Part 1: Test method*

ISO 377, *Steel and steel products — Location and preparation of samples and test pieces for mechanical testing*

ISO 2566-1, *Steel — Conversion of elongation values — Part 1: Carbon and low alloy steels*

ISO 3183, *Petroleum and natural gas industries — Steel pipe for pipeline transportation systems*

ISO 4885, *Ferrous materials — Heat treatments — Vocabulary*

ISO 6892-1, *Metallic materials — Tensile testing — Part 1: Method of test at room temperature*

ISO 6892-2, *Metallic materials — Tensile testing — Part 2: Method of test at elevated temperature*

ISO 6507-1:2018, *Metallic materials — Vickers hardness test — Part 1: Test method*

ISO 7005-1, *Pipe flanges — Part 1: Steel flanges for industrial and general service piping systems*

ISO/TS 7705:2017, *Guidelines for specifying Charpy V-notch impact prescriptions in steel specifications*

ISO 9327-1, *Steel forgings and rolled or forged bars for pressure purposes — Technical delivery conditions — Part 1: General requirements*

ISO 9712, *Non-destructive testing — Qualification and certification of NDT personnel*

ISO 10474, *Steel and steel products — Inspection documents*

ISO 10893-4, *Non-destructive testing of steel tubes — Part 4: Liquid penetrant inspection of seamless and welded steel tubes for the detection of surface imperfections*

ISO 10893-5, *Non-destructive testing of steel tubes — Part 5: Magnetic particle inspection of seamless and welded ferromagnetic steel tubes for the detection of surface imperfections*

ISO 13623, *Petroleum and natural gas industries — Pipeline transportation systems*

ISO 15590-1, *Petroleum and natural gas industries — Induction bends, fittings and flanges for pipeline transportation systems — Part 1: Induction bends*

ISO 15590-2, *Petroleum and natural gas industries — Factory bends, fittings and flanges for pipeline transportation systems — Part 2: Fittings*

ISO 15590-4, *Petroleum and natural gas industries — Factory bends, fittings and flanges for pipeline transportation systems — Part 4: Factory cold bends*

EN 10204, *Metallic components: Types of inspection documents*

EN 10228-1, *Non-destructive testing of steel forgings — Part 1: Magnetic particle inspection*

EN 10228-2, *Non-destructive testing of steel forgings — Part 2: Penetrant testing*

ASME BPVC Section VIII-Rules for construction of pressure vessels division 1

ASME BPVC Section VIII-Rules for construction of pressure vessels division 2

ASME B16.5-20, *Pipe flanges and flanged fittings — NPS 1/2 through NPS 24*

ASME B16.36, *Orifice flanges*

ASME B16.47, *Large diameter steel flange — NPS 26 through NPS 60*

ASTM E112, *Standard test methods for determining average grain size*

ASTM E165, *Standard practice for liquid penetrant testing for general industry*

ASTM E709, *Standard guide for magnetic particle testing*

ANSI/MSS SP-44, *Steel pipeline flanges*

NACE TM 0177-2016-SG, *Standard test method — Laboratory testing of metals for resistance to sulfide stress cracking and stress corrosion cracking in H₂S environments*

NACE TM 0284-2016-SG, *Standard test method — Evaluation of pipeline and pressure vessel steels for resistance to hydrogen-induced cracking*

3 Terms and definitions

For the purposes of this document, the following terms and definitions apply.

ISO and IEC maintain terminology databases for use in standardization at the following addresses:

- ISO Online browsing platform: available at <https://www.iso.org/obp>
- IEC Electropedia: available at <https://www.electropedia.org/>

3.1

ANSI rating class

numerical pressure design class defined in ASME B16.5 and used for reference purposes

Note 1 to entry: The ANSI rating class is designated by the word “Class” followed by a number.

3.2

by agreement

agreed between manufacturer and purchaser

3.3

heat

batch of steel prepared in one steel-making process

[SOURCE: ISO 15590-1:2018, 3.9, modified]

3.4

imperfection

discontinuity or irregularity in the product wall or on the product surface that is detectable through by inspection methods

3.5

manufacturing procedure specification

MPS

document that specifies the process control parameters and the acceptance criteria applied for all manufacturing, inspection and testing activities performed during flange manufacture

[SOURCE: ISO 15590-2:2021, 3.5, modified]

3.6

matching pipe

specified pipe grade and thickness to which the flange will be attached

3.7

pressure class

numerical pressure design class expressed in accordance with either the nominal pressure class or the ANSI rating class

Note 1 to entry: In this document, the pressure class is stated by the nominal pressure class followed by the ANSI rating class between brackets.

3.8

test unit

flange or test piece of the same type, starting material, wall thickness, heat, manufacturing procedure specification, and heat treatment condition

4 Symbols and abbreviated terms

A_0 original cross-sectional area of the parallel length of a test specimen

E_c carbon equivalent

P_{cm}	crack measurement parameter (see Table 4)
S	sour service
t	specified wall thickness at the welding ends for flanges
$T_{d,min}$	minimum design temperature
T_{max}	maximum Charpy V-notch test temperature

CE	carbon equivalent
DN	nominal diameter
HIC	hydrogen-induced cracking
HV	Vickers hardness
MPS	manufacturing procedure specification
MT	magnetic particle testing
NDT	non-destructive testing
NPS	nominal pipe size
PN	nominal pressure
RTJ	ring type joint
SMYS	specified minimum yield strength
SMTS	specified minimum tensile strength
SSC	sulfide stress cracking
UT	ultrasonic testing

5 Designation of flanges

Designation of flanges according to this document, i.e. ISO 15590-3, shall take the form:

ISO 15590-3 YY,

where YY is a textual description of the type of flange designation as specified in [Table 1](#).

Table 1 — Flange designations

Non-sour service		Sour service	
Temperature, $T_{d,min}$ °C	Flange designation	Temperature, $T_{d,min}$ °C	Flange designation
≥0	(N)	≥0	(NS)
<0	(L)	<0	(LS)
N: normal service NS: normal sour service L: low-temperature service LS: low-temperature sour service			

Flanges with a minimum design temperature lower than 0 °C shall demonstrate proven notch toughness in accordance with [Clause 9](#).

Flanges intended for sour service shall be so specified by the purchaser and meet the applicable requirements of [Clause 9](#).

6 Pressure class and design

The flange shall be capable of withstanding an internal pressure equal to the working pressure at the temperature range required. Maximum pressures for the various pressure classes against temperature are shown in [Table 2](#).

Table 2 — Maximum pressures as a function of temperature

Temperature °C	PN											
	20		50		100		150		250		420	
	Class											
	150		300		600		900		1 500		2 500	
	MPa	(bar)	MPa	(bar)	MPa	(bar)	MPa	(bar)	MPa	(bar)	MPa	(bar)
-30 to 120	1,96	(19,6)	5,11	(51,1)	10,2	(102)	15,3	(153)	25,5	(255)	42,6	(426)
150	1,9	(19)	4,93	(49,3)	9,86	(98,6)	14,8	(148)	22,6	(226)	37,7	(377)
175	1,83	(18,3)	4,75	(47,5)	9,51	(95,1)	14,3	(143)	22,2	(222)	34,1	(341)
200	1,76	(17,6)	4,59	(45,9)	9,17	(91,7)	13,8	(138)	21,9	(219)	36,5	(365)
250	1,7	(17)	4,41	(44,1)	8,86	(88,6)	13,3	(133)	22,5	(225)	35,5	(355)
For any temperature below 30 °C, the rating shall be no greater than the rating shown for -30 °C. For intermediate temperatures, linear interpolation should be used. Ratings of flanges for temperatures greater than those given shall be by agreement.												

If there are any deviations from the flange dimensions specified in ASME B16.5 or ASME B16.47, pressure-containment calculations shall be made in accordance with an agreed pressure-vessel design standard such as ASME BPVC Section VIII, Division 1 or Division 2.

The design calculations shall be available for review.

For pipeline applications, the design criteria shall be in accordance with ISO 7005-1.

NOTE External loads or moments are not covered by this document. However, swivels and anchor flanges can experience external loads and can be designed using the equivalent pressure method.

7 Information supplied by the purchaser

The purchaser shall provide the following information in the order given below:

- a) flange designation;
- b) size and class;
- c) quantity of flanges;
- d) material grade;
- e) wall thickness, specified minimum yield strength and bore size for the matching pipe;
- f) flange facing (e.g. raised face, RTJ).

If applicable, the purchaser shall specify the following supplementary information:

- a) minimum design temperatures;
- b) maximum design temperatures;
- c) special dimensional requirements;
- d) design conditions (design pressure, design factor, corrosion allowance and design code);
- e) requirements for supplementary inspection and testing;
- f) pipeline design standard or design factors, if different from ISO 13623 (e.g. anchor and swivel flanges);
- g) mechanical property requirements at the maximum design temperature;
- h) activities for witnessing and approval by purchaser;
- i) marking requirements, if different from this document;
- j) packaging and shipping instructions;
- k) third-party inspection organization;
- l) ISO 10474 or an equivalent regional standard, EN 10204, standard designation of inspection document required.

8 Manufacturing

Flanges shall be manufactured in accordance with a documented MPS, which includes all of the necessary steps to be taken in the manufacture of flanges in accordance with this document. The MPS shall address the information listed in [Clause 7](#) as applicable. Additional details may be required in the MPS prior to the commencement of manufacturing.

An approval of the MPS may be required, either by review of the manufacturer's previous production data or by performance of the mandatory tests listed in [Table 3](#), at the beginning of production.

Forgings shall meet the requirements of ISO 9327-1. The starting material for forged flanges shall be ingot, bloom, billet, slab, plate (for blind flanges only) or bar and shall be fully killed steel. Steel shall be produced by basic oxygen or electric arc furnace process. Steel shall be made to fine grain practice. Flanges shall not be machined from bars.

The material designation shall be consistent with ISO 3183.

Pipeline applications shall be in accordance with ASME B16.5-2020, 6.7. Hubs shall be single slope or dual slope in accordance with ASME B16.5.

Heat-treatment vocabulary shall be in accordance with ISO 4885.

Forged flanges shall be normalized, normalized and tempered, or quenched and tempered after forming. The heat treatment shall be performed in accordance with a documented procedure. The procedure shall define the following parameters, where appropriate, for the type of heat treatment:

- a) heating schedule;
- b) soaking temperature;
- c) soaking time;
- d) cooling schedule;
- e) quenching temperature;
- f) quenching medium, including commencing and final medium temperature;
- g) maximum transfer time to quench.

A record shall be maintained for each heat treatment. Submission of heat treatment record, and heat treatment chart, shall be specified at PO stage and it shall be included in the inspection document.

The tolerances on soaking temperature shall be ± 15 °C and on soaking time ± 20 %.

9 Testing and inspection

Testing and inspection shall be carried out on flange forgings after final heat treatment.

If the pipeline installation techniques will require post-weld heat treatment of the flange, additional testing may be requested to demonstrate that the mechanical properties of the flange are achieved after post-weld heat treatment. Details of the post-weld heat treatment cycle to be used during pipeline installation shall be specified.

The test requirements and acceptance criteria shall be by agreement.

Mechanical testing samples shall consist of a prolongation, or sacrificial forging. By agreement, a separately forged test bar of the same heat as for the final forgings shall be supplied. This test bar shall receive the same approximate working and shall be heat-treated with the flange forgings it represents.

The extent of testing and inspection to be performed shall be as stated in [Table 3](#). Locations for the test pieces to be taken from a flange forging shall be in accordance with ASTM A 370, $1/4 t \times t$, or as established by agreement.

Flanges heat treated within the tolerance requirements of [8.4](#) shall be considered as being in the same heat treatment condition.

Table 3 — Number of tests for destructive physical testing

Type of test	Number and frequency of testing
chemical composition	one per heat
tensile – base metal	one per test unit
impact – base metal	one set per test unit, if applicable
through-thickness hardness	by agreement for NS and LS
surface hardness	by agreement
metallography	one per test unit for NS and LS
HIC	by agreement
SSC	by agreement
NDT	by agreement

Surface hardness may be performed during qualification and then used as a non-destructive reference point for production to quickly determine if production pieces are being produced in the same manner as the qualification piece.

The product analysis shall be in accordance with [Table 4](#).

Table 4 — Chemical composition for product analyses

Element	Maximum permitted alloy content	
	mass fraction, %	
	Lower than Grade 290	Grade 290 and higher
C	0,20	0,18
Mn	1,35	1,60
Si	0,40	0,50
P	0,015	0,015
S	0,005	0,005
V	0,10	0,10
Nb	0,05	0,10
Ti	0,025	0,025
Cr	0,30	0,30
Mo	0,12	0,25
Ni	0,40	1,00
Cu	0,40	1,50
Al ^b	0,05	0,05
N ^b	0,012	0,012
B	0,001	0,000 5 ^a
Ca	0,006	0,006
P_{cm} ^{d e}	0,22	0,22
E_c ^{c e}	0,45	0,43

^a Boron shall not be intentionally added. Boron product analysis is not always accurate below 0,001 % (see ASTM E415[2]).

^b The total Al:N ratio shall not be less than 2:1.

^c Carbon equivalent, E_c , calculated as follows: $E_c = C + \frac{Mn}{6} + \frac{Cr + Mo + V}{5} + \frac{Ni + Cu}{15}$.

^d Crack measurement parameter, calculated as follows:

$$P_{cm} = C + \frac{Si}{30} + \frac{Ni}{60} + \frac{V}{10} + \frac{Mo}{15} + \frac{Cr + Mn + Cu}{20} + 5B$$

^e Based upon product analysis. carbon equivalent limits apply if $C > 0,12$ % and the P_{cm} limits apply if $C \leq 0,12$ %.

9.4.1 Preparation of test pieces

Test pieces shall be prepared in accordance with ISO 377. If thermal cutting has been used to remove samples, the full extent of the heat-affected region shall be removed during the preparation of the test pieces.

9.4.2 Tensile testing

9.4.2.1 Test pieces

Orientation of the base-metal test pieces shall be longitudinal to the major axis of the flange in the weldneck hub. The largest possible round test specimen shall be obtained (see [Figure 1](#)). Tensile testing representing blind or blank flanges may be taken from forged test bars that have received approximately the same amount of working as the blind or blank flanges they represent.

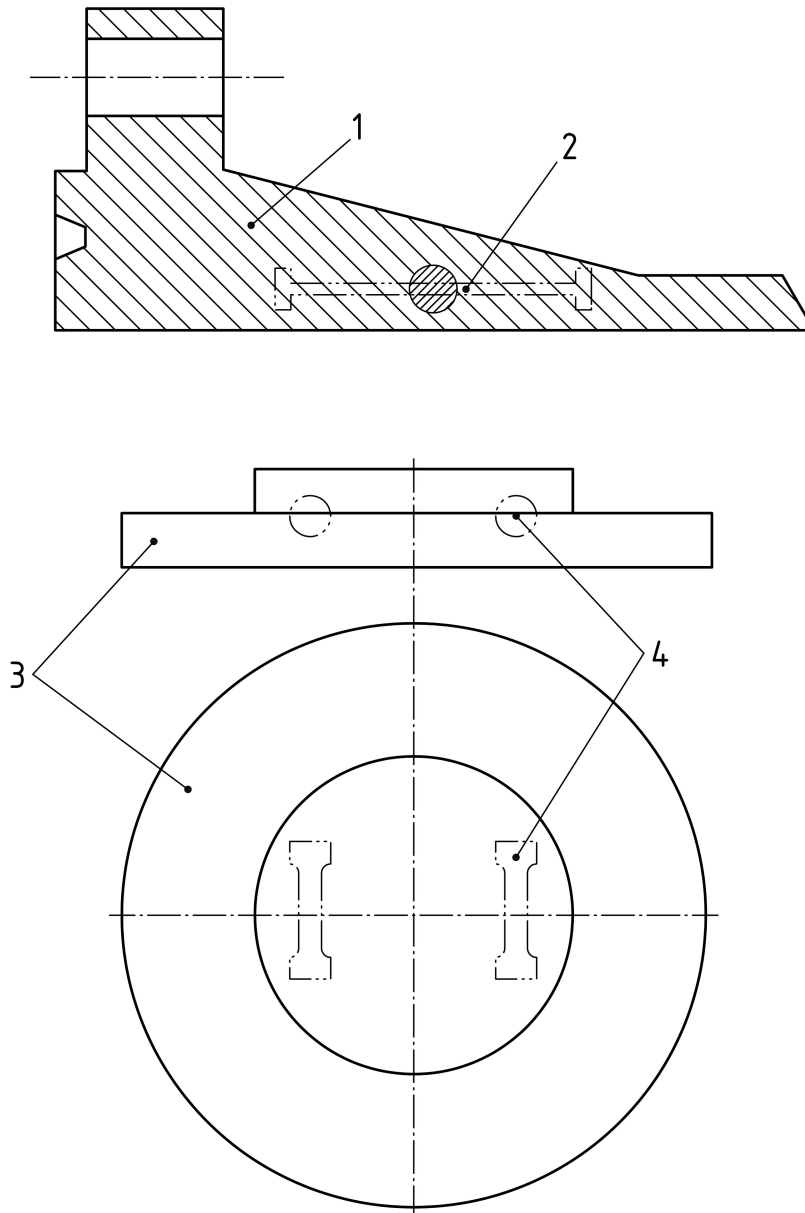

Key

- 1 welding neck flange
- 2 longitudinal tensile specimens
- 3 blind flange
- 4 transverse tensile specimens

Figure 1 — Location of tensile test specimens

9.4.2.2 Test method

Tensile testing at ambient temperature shall be carried out in accordance with ISO 6892-1. If specified, tensile testing at elevated temperatures shall be carried out in accordance with ISO 6892-2.

The frequency of all testing shall meet the requirements of [Table 3](#).

For tensile tests, percentage elongation after fracture shall be determined. The percentage elongation after fracture shall be reported with reference to a gauge length of $5,65\sqrt{A_0}$. If other gauge lengths are

used, the elongation referred to a gauge length of $5,65\sqrt{A_0}$ shall be determined in accordance with ISO 2566-1.

9.4.2.3 Requirements

The material used shall meet the requirements of [Table 5](#).

Table 5 — Mechanical properties by steel grade

Steel grade SMYS	SMTS	Elongation	Minimum average Charpy V-notch value	Minimum Charpy V-notch value
MPa	MPa	%	J	J
245	415	22	27	22
290	415	21	30	24
360	460	20	36	30
415	520	18	42	35
450	535	18	45	38
485	570	18	50	40
555	625	18	56	45

The tensile requirements for intermediate grades shall be obtained by interpolation between those specified for standard grades.

9.4.3 Charpy V-notch impact tests

9.4.3.1 Test pieces

Charpy V-notch test pieces shall be prepared in accordance with ISO 148-1 with the axis of the notch perpendicular to the flange surface.

The orientation and size of the test pieces shall be as follows:

- a) transverse with the greatest possible width between 10 mm and 5 mm (see example in [Figure 2](#));
- b) if transverse test pieces with a minimum width of 5 mm are not possible, longitudinal test pieces with the greatest possible width between 10 mm and 5 mm shall be used;
- c) Charpy V-notch impact testing shall be in accordance with ISO 148-1 with the additional requirement to report % shear area at the fracture surface;
- d) each set of impact tests shall consist of three adjacent test pieces.

The impact test temperature shall be established in accordance with [Table 6](#).

Transverse Charpy specimens shall be notched through-thickness. The actual location shall be that nearest to the welded end from which 10 mm × 10 mm Charpy specimens can be taken.

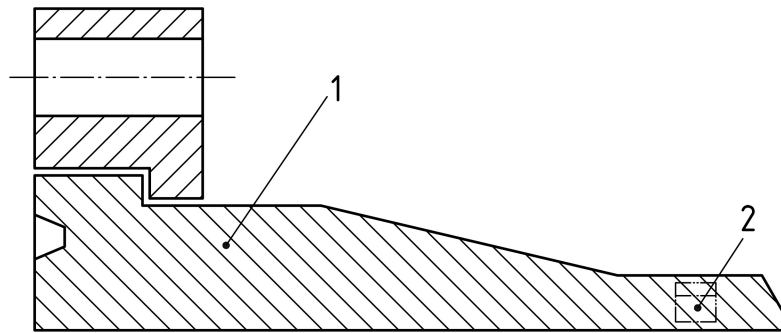

Key

- 1 swivel ring flange
- 2 specimen location

Figure 2 — Location of Charpy V-notch testing specimens (example for a swivel ring flange)

Table 6 — Maximum Charpy V-notch test temperature by category

Nominal wall thickness mm	T_{\max} for N and NS °C	T_{\max} for L and LS °C
$t = 20$	0	-10
$20 < t \leq 25$	0	-20
$t > 25$	0	by agreement

9.4.3.2 Requirements

Charpy V-notch tests shall be carried out in accordance with ISO 148-1.

The minimum average absorbed energy, in joules, of the Charpy V-notch impact tests in the transverse direction shall meet the requirements in [Table 5](#).

The minimum average and individual Charpy V-notch values when testing test pieces taken in the longitudinal direction shall be at least 1,5 times the values stated for transverse test pieces.

If specified, the minimum average shear area shall be 50 % of the fracture surface for any set of tests and all individual test pieces shall exhibit at least 40 % fibrous shear.

For subsidiary test pieces, the minimum required absorbed energy values shall be adjusted in accordance with ISO/TS 7705:2017, Clause 6.

9.4.4 Hardness requirements

9.4.4.1 General

Through-thickness hardness testing shall be performed using the Vickers method in accordance with ISO 6507-1:2018, method HV10 (i.e. with a test force of 98,07 N).

Hardness indent locations for flanges shall be by agreement.

9.4.4.2 Acceptance criteria

No hardness reading shall exceed

- 250 HV10 for sour-service flange forgings, and
- 300 HV10 for non-sour service-flange forgings.

9.4.5 Metallographic examination

9.4.5.1 Test method

Grain-size shall be determined in accordance with ASTM E112.

9.4.5.2 Requirements

The photomicrographs shall demonstrate that the manufacturing process and any subsequent heat treatment have produced a consistent microstructure without separations in the base metal.

9.4.5.3 Acceptance criteria

Forged flanges shall have an average grain-size number of 7 or finer.

9.4.6 HIC tests

If HIC testing is specified, the test procedures and acceptance criteria shall be in accordance with NACE TM 0284-2016-SG.

9.4.7 SSC tests

If SSC testing is specified, test procedures and acceptance criteria shall be in accordance with NACE TM 0177-2016-SG.

9.5.1 NDT procedures and personnel

NDT shall always be performed after final heat treatment.

All NDT shall be conducted in accordance with documented procedures. If specified by the purchaser, NDT procedures shall be decided by agreement before commencement of flange manufacture.

All NDT personnel shall be competent in accordance with ISO 9712 or equivalent to the appropriate level of competence. The minimum level of competence for UT shall be NDT level 2.

NOTE The pressure-vessel or similar industry would be an acceptable sector for the specific examination of ISO 9712.

9.5.2 Forging preparation

All NDT for acceptance of forgings in accordance with the requirements of this document shall be performed after final heat treatment of forgings, except that the surfaces of forgings shall be finished so that surface imperfections can be detected by visual inspection.

The surface to be examined and all adjacent areas within 25 mm shall be dry and free from all dirt, grease, lint, scale, welding flux and spatter, oil or other extraneous matter that could interfere with NDT.

9.5.3 Visual inspection

Forged flanges shall be free from dents with sharp bottom gouges or dents exceeding 3 mm in depth.

The depth of a gouge or dent shall be measured as the maximum distance between the contour of the gouge or dent and the normal flange contour.

9.5.4 MT/PT inspection

9.5.4.1 Test method

The weld-end of flanges shall be inspected by MT in accordance with ISO 10893-5 for the presence of laminar imperfections. By agreement, PT or UT inspection may be carried out instead of MT. In case of UT inspection, the probe shall be placed on the inner surface of the flange.

All other areas of the flange shall be MT-inspected after all heat treatment and final machining has been completed. Each flange shall be inspected by MT in accordance with ASTM E709 or a regional equivalent standard, EN 10228-1, or by PT in accordance with ISO 10893-4, ASTM E165 or a regional equivalent standard, EN 10228-2.

The MT technique should employ fluorescent ink or colour contrast.

9.5.4.2 Requirements

A percentage test shall be by agreement, provided a minimum of 10 % of the batch is tested.

Laminar or linear imperfections equal to or greater than 2 mm in the circumferential direction and with an area exceeding 100 mm² shall not be permitted.

If any unacceptable imperfection is found on the test sample, then 100 % testing shall be carried out on the batch.

Imperfections not classified as defects are permitted to remain in the flange without repair. Localized grinding, however, is permitted.

All dressable surface defects shall be dressed out by grinding. Grinding shall be carried out in such a way that the dressed area blends in smoothly with the contour of the flange. Complete removal of defects shall be verified by local visual inspection aided, if necessary, by suitable NDT methods.

9.5.5 Ultrasonic inspection

9.5.5.1 Test method

The final 50 mm of each end of the flange shall be UT-inspected for the detection of laminar imperfections in accordance with ISO 10893-8. UT for the detection of longitudinal and/or transverse imperfections shall be performed after all heat treatment has been completed.

The reference standard shall contain notches for longitudinal imperfections and radially drilled holes for transverse imperfections.

For the purpose of determining the extent of suspect areas, adjacent suspect areas separated by less than twice the minor axis of the imperfection shall be considered as a single imperfection.

9.5.5.2 Requirements

The frequency of testing shall be established by agreement.

Laminar imperfections equal to or greater than 6 mm in the circumferential direction and with an area exceeding 100 mm² shall not be permitted.

9.6.1 Flange dimensions

Dimensions of blind and weldneck flanges shall be in accordance with ASME B16.5-20, B16.36, B16.47 and ANSI/MSS SP-44.

Dimensions of orifice flanges shall be in accordance with ASME B16.36.

Anchor flanges shall be designed in accordance with ISO 13623 or ASME BPVC Section VIII, Division 1 or Division 2.

Swivel-ring flanges shall be designed and calculations shall be made in accordance with an agreed pressure vessel design standard such as ASME BPVC Section VIII, Division 1 or Division 2. Swivel-ring flanges shall be suitable to bolt to existing ISO 7005-1 flanges and shall be compatible with ASME B16.5-20, B16.36, B16.47 and ANSI/MSS SP-44. Swivel-ring flanges should have RTJ-groove-sealing faces.

9.6.2 Tolerances

Tolerances shall be in accordance with the relevant manufacturing standard.

9.6.3 Flange-face finish

Flange-face finish shall be in accordance with the relevant manufacturing standard and [Table 7](#).

Table 7 — Permissible imperfections in raised face flange finish

Pipe size		Maximum radial projection of imperfections which are no deeper than the bottom of the serrations ^a mm	Maximum depth and radial projection ^b of imperfections which are deeper than the bottom of the serrations mm
DN mm	NPS in		
15 to 80	(1/2 to 3)	3	1,5
100 to 150	(4 to 6)	6	3
200 to 350	(8 to 14)	8	4
400	(16)	10	5
450 to 900	(18 to 36)	12	6
950 to 1 200	(38 to 48)	13	6,5
1 250 to 1 500	(50 to 60)	16	8

^a Imperfections less than half the depth of the serrations shall not be cause for rejection.

^b A radial projection shall be measured by the difference between an inner and an outer radius encompassing the imperfection where the radius is struck from the centerline of the bore.

Hydrostatic testing of flanges is not required unless otherwise specified.

Flanged joints may be subjected to system hydrostatic tests at a pressure limited to 1,5 times the 40 °C rating (PN class) rounded off to the next higher one (1) bar. Testing at any higher pressure is by agreement.

The steel used to manufacture flanges shall be suitable to weld to other flanges, pipe manufactured in accordance with ISO 3183 and the bends and fittings manufactured in accordance with the ISO 15590 series.

Proof of field weldability may be required by agreement.

Weld repair of flanges shall be performed only by agreement. Repair welding shall be performed in accordance with specified standards.

ASTM A105-21, Clause 12 and ISO 15590-1:2018, 10.5.8 may be referenced.

Full-thickness repairs are only allowed as long the repair is a double-sided weld (i.e., partial thickness weld from ID with the balance filled from OD) with a qualified procedure.

NOTE Welding of swivel-ring flange retaining rings is outside the scope of this document.

10 Documentation

The purchaser shall specify the required ISO 10474 or an equivalent regional standard, EN 10204, designation of the inspection document and any specific requirements for the format and content of the document.

If required, a manufacturing record book shall be prepared, assembled into sections, indexed, including the following as a minimum:

- flange MPS;
- list of flanges produced, identification and heat numbers;
- original steel maker's or forger's certificates;
- official certificates of mechanical test results, stamped and signed as-approved;
- records of heat treatments, heat treat charts (see [8.4](#));
- NDT results and certificates;
- dimensional inspection reports;
- other documents as required (e.g. inspection documents).

11 Marking

Each flange shall be identified with the marking requirements in accordance with ASME B16.5.

In addition to the above-defined markings, the heat reference shall be die-stamped on the external surface, using low-stress 5 mm rounded or interrupted dot stamps. Smaller stamps may be required on small sized flanges due to space limitations.

Identification markings shall not be stencilled or painted on the weld preparation or the raised face or RTJ groove.

Each flange shall be marked as a minimum with the following information:

- purchase order and item number;
- flange designation, as defined in [Clause 5](#);
- specification and material grade of forging;
- heat number;
- DN and NPS;
- wall thickness, pipe schedule and bore;

- manufacturer's name or trade mark;
- design pressure or class;
- temperature of Charpy V-notch testing;
EXAMPLE 1 -20 °C = M20C;
EXAMPLE 2 +10 °C = P10C.
- any additional marking specified in the purchase order.

Bibliography

- [1] ISO 14313, *Petroleum and natural gas industries — Pipeline transportation systems — Pipeline valves*
- [2] ASTM A105-21, *Standard specification for carbon steel forgings for piping applications*
- [3] ASTM E415, *Standard test method for analysis of carbon and low-alloy steel by spark atomic emission spectrometry*

Price based on 18 pages

© ISO 2022 – All rights reserved

